



**WE ARE  
JETBOX™ & BURNER  
TECHNOLOGY**

**INTECO**  
**PTI** process  
technology  
international



# ABOUT INTECO PTI

---

## WHO WE ARE...

As a member of the INTECO Group since 2013, we contribute 30 years of expertise to an international successful group with a leadership in metallurgical process technology and equipment for melting, refining, casting, remelting and atomization for high performance steels, superalloys and titanium. Our dedicated team of qualified engineers, metallurgists and technical support staff with subsidiaries in Europe and Shanghai ensure global customer satisfaction.

---

## WHAT WE DO...

Our core competencies within the group lie in high-tech applications, particularly chemical energy systems for electric arc furnaces, including oxy-fuel burners, material injection systems as well as control and automation systems, preheating and drying combustion systems to enhance efficiency, productivity and safety. We offer full-service combustion and injection solutions, including design, engineering, manufacturing, testing, commissioning, training and process optimization.

---

## WHAT WE AIM FOR...

Always eager to further develop our products and serve you – our valued customer – with the best equipment possible, we conduct research and submit patents for our innovative and tailor-made solutions.

---

# SAFE CHEMICAL ENERGY FOR YOUR EAF

INTECO PTI's concept has promoted the most aggressive introduction of oxygen and chemical energy into the Electric Arc Furnace (EAF) resulting in dramatic efficiency and utilization improvements. To employ this concept safely, INTECO PTI invented a unique water-cooled copper box (JetBox™) which houses the burner and injector very low inside the EAF at a steep angle.

---

## A huge variety of JetBox™ types

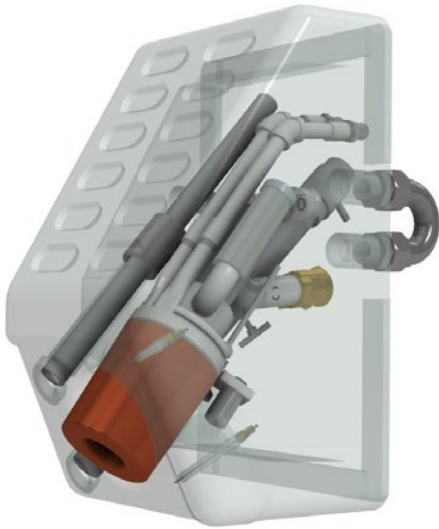

The JetBox™ is designed to position the burner and oxygen injection as close to the steel bath as possible for the highest injection efficiency with no fear of damage to the EAF as it provides excellent cooling protection and is capable of withstanding the impact of falling scrap and splashing of slag and molten metal.

The JetBoxes™ are situated just above the last course of refractory bricks with their front face in line with the hot face of bricks. This location provides the following advantages for the EAF operations:

- › Enables better energy transfer into the scrap while in melting mode
- › Minimizes plugging from splashing slag and molten metal during EAF operation
- › Eliminates overheating problems in adjacent panels by moving the burner further from the panels' hot face
- › Promotes higher oxygen efficiency due to shorter jet length and the ability to use the optimal injection angle
- › Allows carbon and lime injection to be applied closer to the molten bath promoting better foamy slag and minimizing material losses

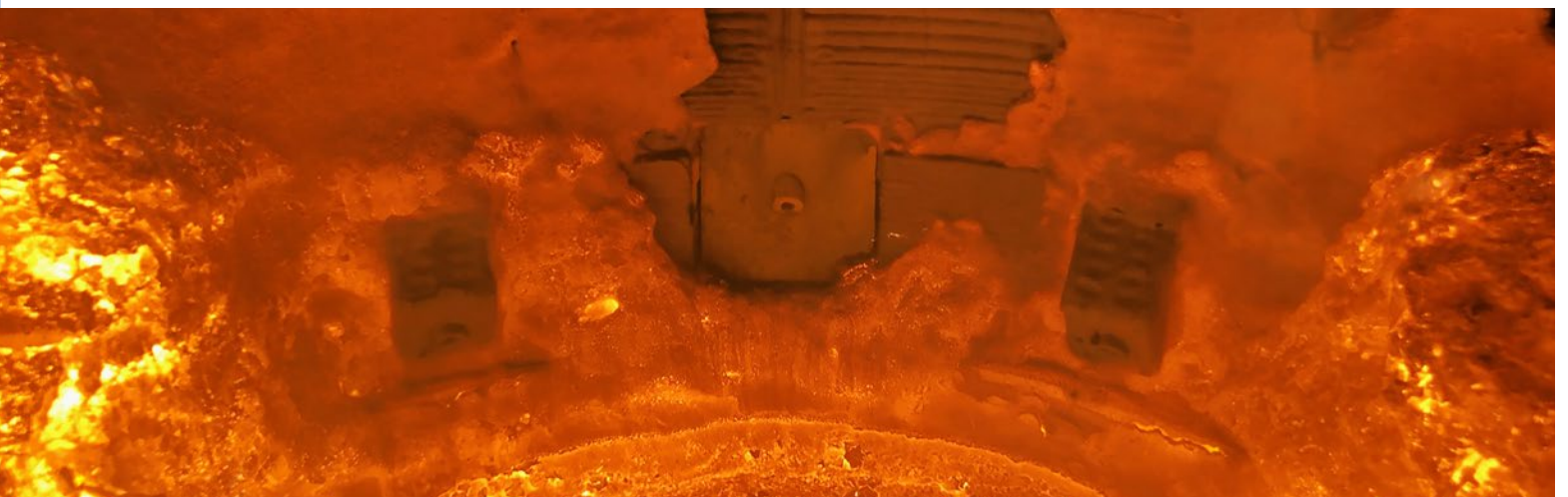



### Cast JetBOx™

- › standard (35.5x22x20,5", 1985lbs)
- › 1 or 2 ports at different port position and sizes



### Forged JetBOx™

- › standard size
- › mini Forged JetBOx™
- › 1 or 2 ports at different port position and sizes



### Hybrid JetBOx™

- › cast host and machined front face
- › available in standard size
- › 1 or 2 ports at different port position and sizes

# We are (a burner) family

We offer different burner models and regardless of the burner type – they all have the same size to fit into all type of JetBOXes™.

## Combined burner and supersonic oxygen injector

The INTECO PTI JetBurner™ is both a standard oxy-fuel burner and a gas shrouded supersonic oxygen injector. The JetBurner™ produces a highly efficient flame and enables the oxygen to travel in a tight stream over a large distance.

## Oxygen only supersonic injectors

While not as efficient as the shrouded oxygen injector, the oxygen-only, supersonic injectors provide highly velocity oxygen to processes that cannot use or do not have a combustible gas available.

## Special application burners & Injectors

Some processes cannot use the standard PTI burner. For these processes, INECO PTI has developed special application burner/injectors. INTECO PTI can design a burner to fit the unique aspects of your process.

## Material injectors

INTECO PTI has developed a supersonic oxygen injector that allows material injection during process. This injector clears an area inside the furnace so that material can be injected through the burner without blocking of the injection port or build-up within the furnace. Burner only applications are also available.

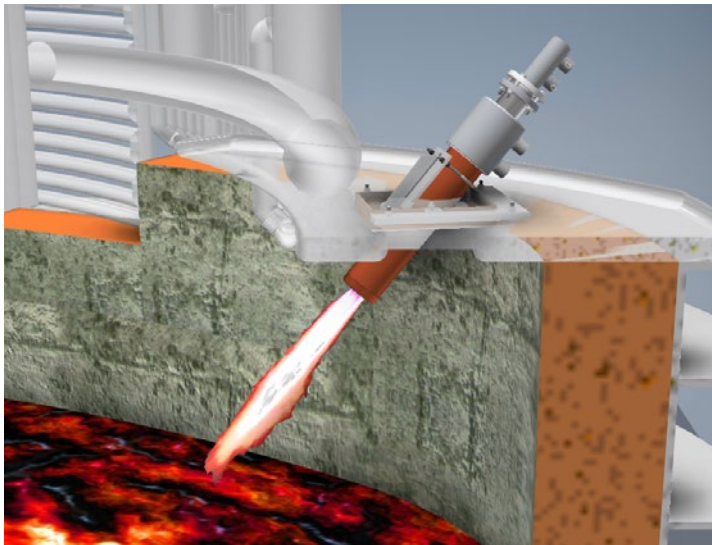

## Our Technology – Your Advantage

- › Typical burner power up to 5MW
- › Larger custom burner sizes are available
- › Fuel types available: natural gas, LPG & diesel - others on request
- › Supersonic oxygen injector (sizes start at 330 SCFM (530 Nm<sup>3</sup>/h) and are as large as 2,800 SCFM (4,500 Nm<sup>3</sup>/h)
- › All burners and injectors fit the standard INTECO PTI side-wall gland or PTI JetBOX™
- › The annulus burner provides a port to inject material into the process through the sidewall



INTECO PTI PROCESS TECHNOLOGY INTERNATIONAL, LLC



4950 S Royal Atlanta Drive, Suite A  
Tucker, GA 30084 USA  
+1 770 934 9502  
sales@intecopti.com

[www.intecopti.com](http://www.intecopti.com)